

1	2	3	4	5	6
版本 (REV.)	描述 (DESCRIPTION)	变更号 (ECN NO.)	签名 (NAME)	日期 (DATE)	
0	FIRST EDITION	N/A	YWD	2020-07-02	



所有物料及工艺
必须符合
ROHS要求

ALL PARTS MUST
MEET TO ROHS
REQUIREMENTS

样品图
2020.07.06
文控中心

REMARKS:
1. CONTACT PIN TO SOLDER

作废

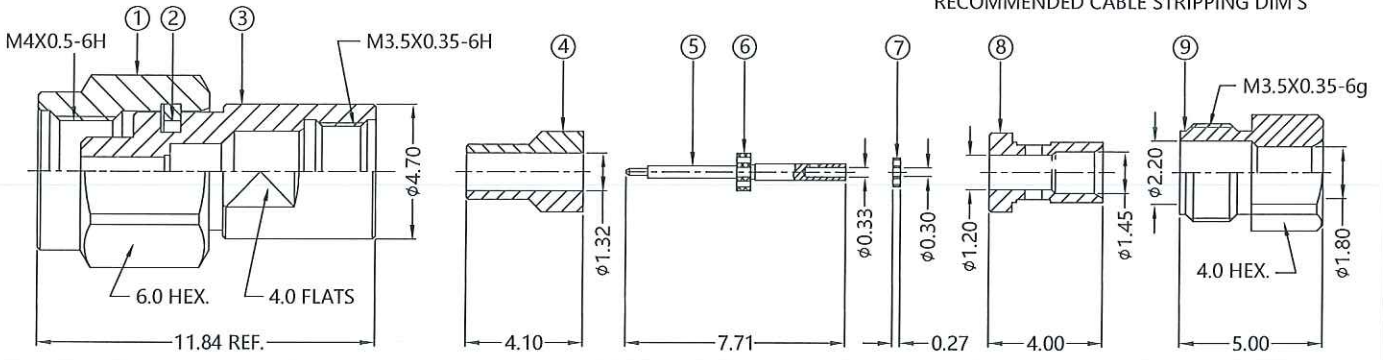
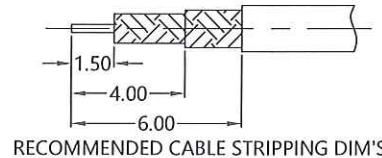

- NOTES: FINISH (PLATING THICKNESS IN MICRO-INCHES)
1. STAINLESS STEEL 316F
 2. UNFILLED ULTEM1000 PEI
 3. BERYLLIUM COPPER C17300
 4. BERYLLIUM COPPER C17 200
 5. BRASS C3604
 6. GOLD PL. 10 u" MIN, OVER NICKEL PL. 100-200 u", THICK OVER COPPER STRIKE
 7. GOLD PL. 30 u" MIN, OVER CHEMICAL NICKEL PL. 20-50 u"
 8. PASSIVATION
 9. UNFILLED PEEK

9	BARREL	NOTE 1	NOTE 8	1	T-BRT1001A/SS
8	FERRULE	NOTE 5	NOTE 6	1	FRT1001A/BR
7	INSULATOR	NOTE 9	N/A	1	INT1003A/PK
6	INSULATOR	NOTE 2	N/A	2	INT1001A/PI
5	CONTACT PIN	NOTE 3	NOTE 7	1	T-CPT1003A/BE
4	BODY	NOTE 1	NOTE 8	1	T-BDT1008A/SS
3	BODY	NOTE 1	NOTE 8	1	T-BDT1005A/SS
2	RETAIN RING	NOTE 4	N/A	1	RTT1001A/BE
1	SHELL	NOTE 1	NOTE 8	1	T-SHT1002A/SS
NO.	DESCRIPTION	MATERIAL	FINISH	Q'TY	DRAWING NO.

材料与电镀 (MATERIALS AND PLATING) UNIT: MICRO-INCHES		
PART NAME	MATERIALS	PLATING
主体 BODY	不锈钢 STAINLESS STEEL 316F	钝化 PASSIVATION
绝缘体 INSULATOR	PEI	N/A
中心针 CONTACT PIN	铍铜 C17300 BERYLLIUM COPPER	化学镍底 20~50 u" / 镀金 30 u" GOLD 30 u" / CHEMICAL NICKEL 20-50 u"
密封圈 GASKET	硅橡胶 SILICONE	N/A

电气性能 (ELECTRICAL CHARACTERISTICS)	
特性阻抗 (Impedance)	50 Ω
工作电压 (Voltage rating)	170 V(rms)
频率范围 (Frequency range)	DC ~ 110 GHz
介质耐压 (Dielectric withstanding voltage)	> 500 V
接触电阻 (Contact resistance)	内导体 (Center contact) < 4.0 mΩ 外导体 (Outer contact) < 1.0 mΩ
绝缘电阻 (Insulation resistance)	> 5000 MΩ
插入损耗 (Insertion loss)	0.05x√f (GHz) dB
电压驻波比 (VSWR)	< 1.20 @ 67GHz < 1.35 @ 110 GHz
三阶互调 (3rd Intermodulation)	N/A

机械特性 (MECHANICAL CHARACTERISTICS)	
插拔力 (Force to engage and disengage)	N/A
中心针保持力 (Center contact retention force)	N/A
螺母扭力 (Coupling proof torque)	> 6.2 in-lbs
螺母拉力 (Coupling nut retention force)	> 50 lbs
机械耐久性 (Durability)	> 500 cycles

环境参数 (ENVIRONMENTAL PARAMETER)	
工作温度 (Temperature range)	-40 °C ~ +125 °C

除非特别声明 (UNLESS OTHERWISE SPECIFIED):
 1) 未注倒角 (EDGES): C0.15 MAX;
 2) 去除各处毛刺 (REMOVE ALL BURRS);
 3) 表面光洁度 (SURFACE ROUGHNESS): Ra0.8;
 4) 单位: 毫米 (UNITS: mm);
 5) 未标注尺寸公差 (DIMENSIONS TOLERANCES)
 小数 (DECIMALS) .x ±0.2, .xx ±0.1, .xxx ±0.05;
 角度 (ANGLES) ±3°.

第三视角 (THIRD ANGLE PROJECTION)	
批准 (APPROVED):	客户料号 (CUSTOMER P/N):
审核 (CHECKED):	比例 (SCALE):
制图 (DRAWING):	日期 (DATE): 2020-07-02
	PAGE: 1/1

SLK
SUPERLINK

标题 (TITLE):
1.0mm MALE S/T FOR SPB-160

图号 (DRAWING NO.):
T-5T1M15S-A659

COMPANY WEBSITE: www.slkcorp.com