

REV.	DESCRIPTION	ECN NO.	NAME	DATE
A6	UPDATE CASING FOR CENTER PIN MATERIAL	N/A	HRWEI	2017-07-06
A7	NEW FRAME	N/A	JING	2020-05-19

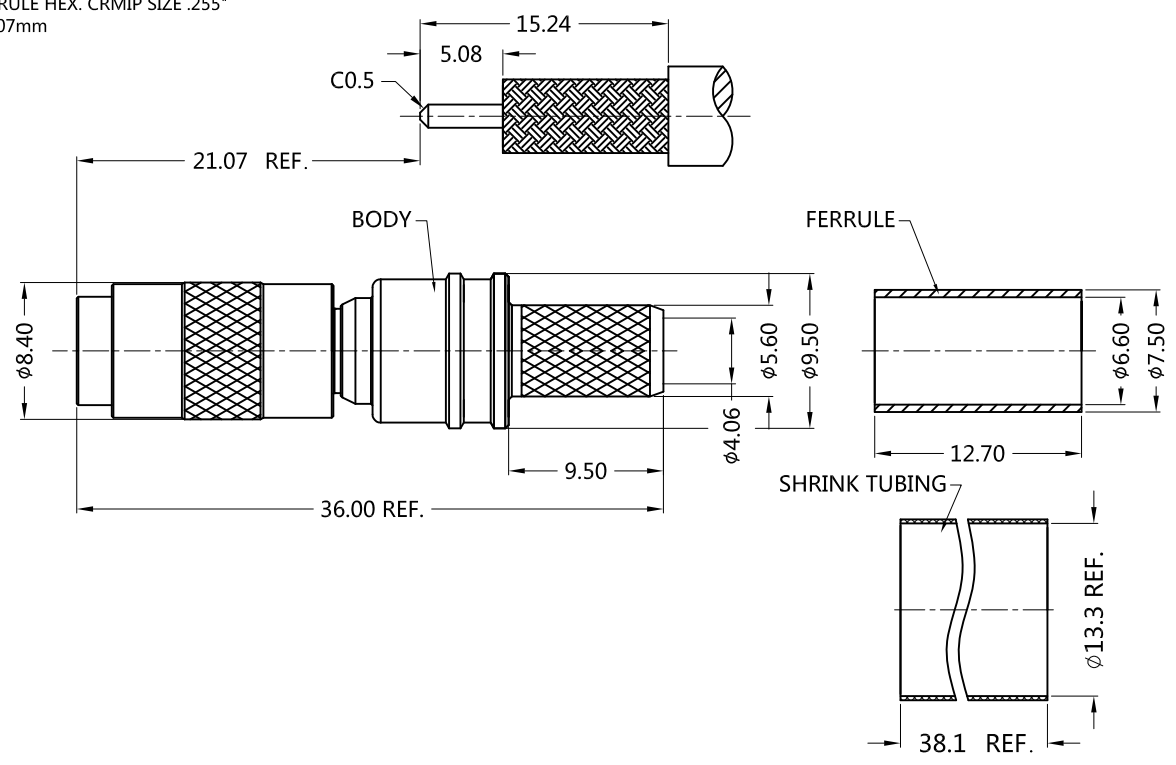

ALL PARTS MUST MEET TO RoHS REQUIREMENTS

REMARKS:
 1. CONTACT PIN TO CAPTIVE
 2. CRIMPED FERRULE HEX. CRMIP SIZE .255"
 3. ADD SIZE: 21.07mm



MATERIALS AND PLATING		UNIT: MICRO-INCHES
PART NAME	MATERIALS	PLATING
BODY	BRASS C3604	ALBALOY 80u"/COPPER
INSULATOR	PTFE ASTM-D-1710	N/A
CONTACT PIN	BERYLLIUM COPPER	GOLD 50 u"/NICKEL/COPPER
FERRULE	BRASS	ALBALOY 80u"/COPPER

ELECTRICAL CHARACTERISTICS		
IMPEDANCE	50 Ω	
VOLTAGE RATING	250 V(rms)	
FREQUENCY RANGE	0 ~ 6 GHz	
DIELECTRIC WITHSTANDING VOLTAGE	>750 V	
CONTACT RESISTANCE	CENTER CONTACT	<4.0 mΩ
	OUTER CONTACT	<2.5 mΩ
INSULATION RESISTANCE	>1000 MΩ	
INSERTION LOSS	N/A	
RF-LEAKAGE	N/A	
VSWR	<1.30	
3RD INTERMODULATION	N/A	

MECHANICAL CHARACTERISTICS	
FORCE TO ENGAGE AND DISENGAGE	N/A
CENTER CONTACT RETENTION FORCE	>4 lbs
RECOMMENDED COUPLING TORQUE	N/A
COUPLING NUT RETENTION FORCE	N/A
DURABILITY	>500 cycles

ENVIRONMENTAL PARAMETER	
TEMPERATURE RANGE	-40°C ~ +125 °C

* CUSTOMER OUTLINE DRAWING

UNLESS OTHERWISE SPECIFIED:
 1) EDGES : C0.15 MAX ;
 2) REMOVE ALL BURRS ;
 3) SURFACE ROUGHNESS : Ra1.6 ;
 4) UNITS : mm ;
 5) DIMENSIONS TOLERANCES
 DECIMALS : .x ±0.2 .xx ±0.1 .xxx±0.05;
 ANGLES : ± 3°.

THIRD ANGLE PROJECTION	
APPROVED :	CUSTOMER P/N :
CHECKED :	SCALE :
DRAWING :	DATE :
JING	2020-05-19
PAGE : 1/1	

TITLE : 1.0/2.3 MALE S/T FOR LMR-240 CABLE
 DRAWING NO. : 5A1M11S-A46-003
 COMPANY WEBSITE : www.slkcorp.com

CUSTOMER OUTLINE DRAWING