

REV.	DESCRIPTION	ECN NO.	NAME	DATE	 ALL PARTS MUST MEET TO RoHS REQUIREMENTS
0	FIRST EDITION	N/A	XIAO	2016-01-11	
1	NEEW FRAME	N/A	HYH	2020-07-30	

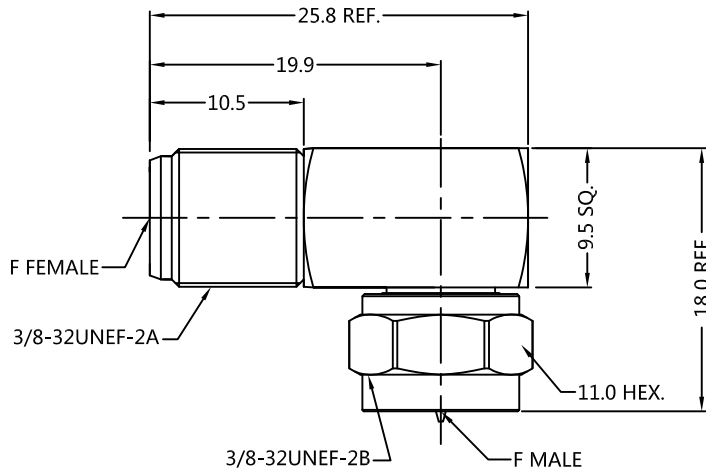

MATERIALS AND PLATING			UNIT: MICRO-INCHES
PART NAME	MATERIALS	PLATING	
BODY/SHELL	BRASS C3604	NICKEL PL.100 u"/COPPER	
CONTACT PIN	BRASS C3604	NICKEL PL.100 u"/COPPER	
CONTACT	PHOSPHOR BRONZE	TIN PL 120u"/COPPER	
INSULATOR	PTFE ASTM-D-1710	N/A	
DIELECTRIC,MIDDLE	DELRIN	N/A	
RATING RING	PHOSPHOR BRONZE	N/A	

ELECTRICAL CHARACTERISTICS		
IMPEDANCE	75 Ω	
VOLTAGE RATING	500 V(rms)	
FREQUENCY RANGE	0 ~ 1 GHz	
DIELECTRIC WITHSTANDING VOLTAGE	>1500 V	
CONTACT RESISTANCE	CENTER CONTACT	<5.0 mΩ
	OUTER CONTACT	<2.5 mΩ
INSULATION RESISTANCE	>1000 MΩ	
INSERTION LOSS	<0.5 dB	
VSWR	<1.8	
3RD INTERMODULATION	N/A	

MECHANICAL CHARACTERISTICS	
FORCE TO ENGAGE AND DISENGAGE	N/A
CENTER CONTACT RETENTION FORCE	>6 lbs
COUPLING TORQUE	N/A
COUPLING NUT RETENTION FORCE	>100 lbs
DURABILITY	>500 cycles

ENVIRONMENTAL PARAMETER	
TEMPERATURE RANGE	-40 °C~+85 °C

**\* CUSTOMER OUTLINE DRAWING**

UNLESS OTHERWISE SPECIFIED:  
 1) EDGES : C0.15 MAX ;  
 2) REMOVE ALL BURRS ;  
 3) SURFACE ROUGHNESS : Ra1.6 ;  
 4) UNITS : mm ;  
 5) DIMENSIONS TOLERANCES  
 DECIMALS : .x ±0.3 .xx ±0.2 .xxx±0.1;  
 ANGLES : ± 5°.

THIRD ANGLE PROJECTION

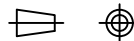

APPROVED :

CUSTOMER P/N :

CHECKED :

SCALE :

2 : 1

DRAWING :

DATE : 2020-07-30

PAGE : 1/1



TITLE : F SERIES CONNECTOR ELBOW ADAPTOR FEMALE-MALE,75Ω

DRAWING NO. :

7FCF06R-FCM

COMPANY WEBSITE : www.slkcorp.com

CUSTOMER OUTLINE DRAWING