

1	2	3	4	5	6
版本(REV.)	描述(DESCRIPTION)	变更号(ECN NO.)	签名(NAME)	日期(DATE)	
0	FIRST EDITION	N/A	XJ	2021-11-01	
1	CHANGE BODY SIZE	N/A	XJ	2021-12-16	

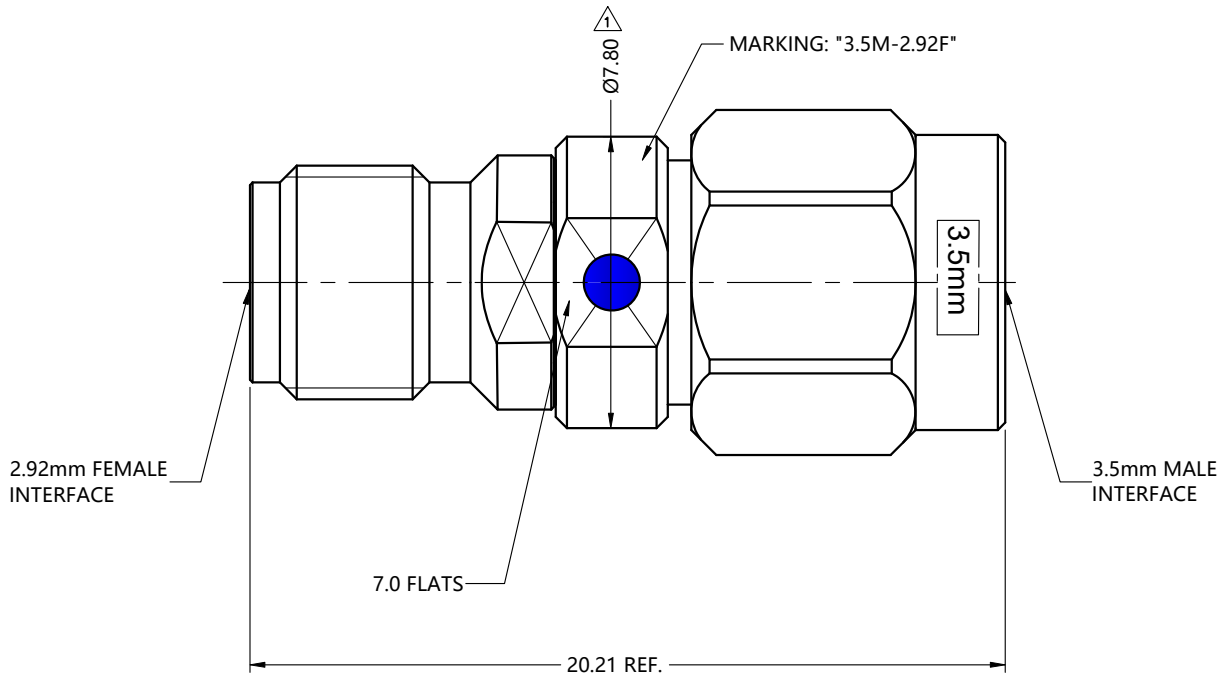

ALL PARTS MUST MEET TO RoHS REQUIREMENTS



MATERIALS AND PLATING			UNIT: MICRO-INCHES		ELECTRICAL CHARACTERISTICS		
PART NAME	MATERIALS	PLATING					
BODY /SHELL	STAINLESS STEEL	PASSIVATION			IMPEDANCE	50 Ω	
CONTACT PIN	BERYLLIUM COPPER	GOLD 50u"/NICKEL			VOLTAGE RATING	250 V(rms)	
INSULATOR	PEI	N/A			FREQUENCY RANG	DC ~ 26.5 GHz	
RETAIN RING	BERYLLIUM COPPER	N/A			DIELECTRIC WITHSTANDING VOLATGE	> 500 V	
					CONTACT RESISTANCE	CENTER CONTACT	<3.0 mΩ
						OUTER CONTACT	<2.0 mΩ
					INSULATION RESISTANCE	> 5000 MΩ	
					INSERTION LOSS	< 0.05 $\times\sqrt{F}$ (GHz) dB	
					VSWR	< 1.20	
					3RD INTERMODULATION	N/A	
MECHANICAL CHARACTERISTICS				ENVIRONMENTAL CHARACTERISTICS			
FORCE TO ENGAGE AND DISENGAGE		N/A		TEMPERATURE RANGE		-55 °C ~ +125 °C	
CENTER CONTACT RETENTION FORCE		> 6 lbs					
COUPLING PROOF TORQUE		11.5-15 in-lbs					
COUPLING NUT RETENTION FORCE		> 60 lbs					
DURABILITY		> 500 cycles					

*CUSTOMER OUTLINE DRAWING:

UNLESS OTHERWISE SPECIFIED:
 1) EDGES: C0.15 MAX;
 2) REMOVE ALL BURRS;
 3) SURFACE ROUGHNESS: Ra0.8;
 4) UNITS:mm;
 5) DIMENSIONS TOLERANCES
 DECIMALS .x ±0.2 .xx ±0.1 .xxx±0.05
 ANGLES ±3°

THIRD ANGLE PROJECTION

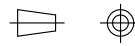

APPROVED:

CUSTOMER P/N:

CHECKED:

SCALE:

5:1

DRAWING:

DATE: 2021-12-16

PAGE: 1/1



TITLE: 3.5mm MALE TO 2.92mm FEMALE S/T ADAPTER,50Ω

DRAWING NO.: T-5P3M06S-P9F-003

COMPANY WEBSITE: www.slkcorp.com

CUSTOMER OUTLINE DRAWING